

**E88-UL / E88C-UL / E88CS-UL / E88O-UL / E85-UL**

**General Description**

- Push-button operated warm air hand dryer with rotating nozzle.
- Long durability and complete reliability, with anti-vandalism features and designed to be installed in high traffic facilities such as airports, large hotels, sport centers, large recreational areas and large official organizations, among others.
- Maximum robustness and power.
- Easy maintenance, low noise levels and a high level of user safety.
- 1/16" (1.5 mm) thick steel cover or a 15/64" (6 mm) thick cast iron cover, these hand dryers are available in 5 different finishes (white enameled coating, bright, satin, gold plated & white porcelain enameled).

**Components & Materials**

- **E88-UL:** 1/16" (1.5 mm) thick steel cover, white enamelled coating finish.
- **E88C-UL:** 1/16" (1.5 mm) thick steel cover, bright finish.
- **E88CS-UL:** 1/16" (1.5 mm) thick steel cover, satin finish.
- **E88O-UL:** 1/16" (1.5 mm) thick steel cover, gold plated finish.
- **E85-UL:** 15/64" (6 mm) thick cast iron cover, white porcelain enameled.
- **COVER:** one-piece steel/cast iron cover fixed to the base by means of 2 vandal-proof lock screws and lock with special Saniflow® wrench.
- **BASE PLATE:** made in aluminum, 1/8" (3 mm) thick, with 4 Ø 5/16" (8 mm) holes for wall mounting.
- **FAN SCROLL:** fire resistant plastic UL 94-VO fan scroll.
- **MOTOR:** universal brush motor, 5,800 rpm, class A, which includes a safety thermal cut-off.
- **FAN WHEEL:** aluminum centrifugal double symmetrical inlet fan wheel.
- **HEATING ELEMENT:** waved wire NiCr heating element on a mica frame that incorporates a thermal cut-off.
- **NOZZLE:** 360° nozzle in chrome plated Zamak.
- **PUSH-BUTTON:** made in chrome plated Zamak that activates an electromechanical timer with a 35 second cycle.
- **SILENT BLOCKS:** 4 to eliminate vibrations.

**Technical Specifications**

Voltage - 110-120V	Total power - 1,850 W
Frequency - 60 Hz	Motor Power - 250 W
Electrical Isolation - Class I	Heating element power: 1,600 W
Dimensions - 11"Wx9 3/4"Hx8 3/8"D <sup>(1)</sup> 11 1/8"Wx10"Hx8 1/2"D <sup>(2)</sup>	Consumption - 16A Cover thickness - 1/16" (1.5 mm) <sup>(1)</sup> / 15/64" (6 mm) <sup>(2)</sup>
Weight - 13 Lbs <sup>(1)</sup> / 25 Lbs <sup>(2)</sup>	r.p.m. - 5,800
Effective airflow - 149 CFM	Air temperature (4" distance/70 °F) 127 °F ( 43 °C)
Air velocity - 62 mph (5,468 LFM)	Drying time - 29 sec.
Protection rating - IP23	Sound pressure <sup>(3)</sup> - 68 dBA

**Operation**

Press the push-button to initiate the drying process, place the hands under the rotating nozzle into the air outlet and rub them together. The dryer will go on with no interruption for 35 seconds.

Please mark the selected item



code  
**E88-UL**

material  
steel  
finish  
white enamelled



code  
**E88C-UL**

material  
steel  
finish  
bright



code  
**E88CS-UL**

material  
steel  
finish  
satin



code  
**E88O-UL**

material  
steel  
finish  
gold plated



code  
**E85-UL**

material  
cast iron  
finish  
white porcelain  
enameled



Saniflow Corp reserves the right to make changes and/or modifications to the products and their specifications without warning or notice.

For further info please contact SANIFLOW on: Toll free: **1-877-222-9125** or visit our website at **www.saniflowcorp.com**  
Tel: +1 (305) 424 2433 Fax: +1 (305) 424 2435 · [sales@saniflowcorp.com](mailto:sales@saniflowcorp.com)

[HandDryerSupply.com](http://HandDryerSupply.com) | 804-859-2498 | [sales@handdryersupply.com](mailto:sales@handdryersupply.com)

## Installation

Verify all rough-in dimensions prior to installation. Hand dryers require a dedicated circuit and must be properly grounded. A GFCI (Ground fault circuit interrupter) is recommended. One side of dryer should be mounted to a stud.

## Certificates & Qualifications

Unit shall be UL and CSA approved, according to UL 499 and CSA C22.2 standards.

## N° dryers to be fitted

- In toilet areas with a normal frequency of use and only one wash-basin: 1 dryer.
- In toilet areas with a normal frequency of use and more than one wash-basin: 1 dryer for each 2-3 wash-basins.
- 1 row of 4 wash basins: 2 dryers; 1 row of 6 wash basins: 3 dryers; 1 row of 8 wash basins: 4 dryers.
- In toilet areas with high traffic and more than one wash-basin: 2 dryers for each 3 wash-basins.
- 1 row of 4 wash basins: 3 dryers; 1 row of 6 wash basins: 4 dryers; 1 row of 8 wash basins: 5 dryers.

## Ideal location

Between the wash-basin and exit. It is not recommended to install dryer between wash-basins, next to urinals, lavatories and showers. If installing automatic dryers over marble surface or ledge, the minimum distance from the dryer to the ledge must be 15-3/4". It is recommended that hand dryers be distributed throughout the washroom area to avoid overcrowding.

## Guide Specification

Surface mounted vandal resistant hand dryer shall be fabricated with 15/64" (6 mm) thick cast iron cover, white porcelain enameled or in one-piece 5/64" thick metal sheet cover, white enameled or chromed bright or chromed satin or chromed gold finish. The back base shall be aluminum, 1/8" thick and with 4 holes for wall mounting. Cover shall be equipped with a chrome-plated 360° revolving nozzle for hand and face drying. The dryer shall be activated using the chrome-plated Zamak 22 μ thick push button that activates an electromechanical timer with a 35 second cycle before switching dryer off automatically. Motor shall be 1/3 hp, 5,800 rpm, universal type, with a 4A fuse with sealed, self-lubricated ball bearing; The waved wire NiCr heating element should incorporate a thermal limiter which will switch off by a temperature of 176 °F (80°C). The fan should be an aluminum centrifugal turbine with double symmetrical inlet, and the fan scroll shall be made of a fire resistant plastic UL 94-V0. Dryer shall deliver 149 CFM of air at 127 °F (43 °C) and 5,468 LFM velocity during user controlled drying cycle. The dryer shall have a total power of 1,850 W with a consumption of 16A. Noise level should be 68 dB. Overall dimensions shall be 11"Wx9 3/4"Hx8 3/8"D (E88-UL / E88C-UL / E88CS-UL / E88O-UL) or 11 1/8"Wx10"Hx8 1/2"D (E85-UL). Unit shall be UL and CSA certified.

Surface-Mounted Hand Dryer shall be models E88-UL, E88C-UL, E88CS-UL, E88O-UL or E85-UL of Saniflow Corporation, 3325 NW 70th Avenue, Miami, FL 3312, USA.

## Overall dimensions:

**E88-UL / E88C-UL / E88CS-UL / E88O-UL:** 11"W x 9 3/4"H x 8 3/8" (278 x 248 x 212 mm)

Weight: 13 Lbs

**E85-UL:** 11 1/8"Wx10"Hx8 1/2"D (282 x 255 x 215 mm) Weight: 25 Lbs

## Recommended heights from floor

	Male	Female	Child	Disabled
<b>x</b> To top of machine	56" / 142 cm	54" / 137 cm	46" / 117 cm	48" / 122 cm
<b>y</b> To mounting bracket screw	55" / 140 cm	53" / 135 cm	45" / 115 cm	47" / 120 cm
<b>z</b> To sensor top	46" / 117 cm	44" / 112 cm	36" / 92 cm	38" / 97 cm

## MOUNTING

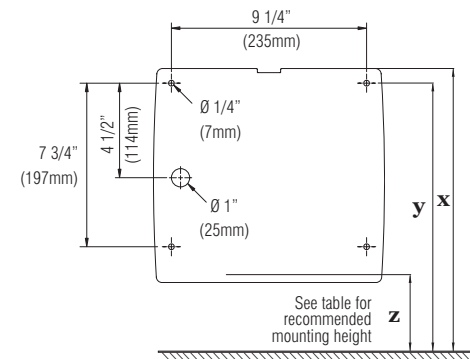

## E88-UL / E88C-UL / E88CS-UL / E88O-UL

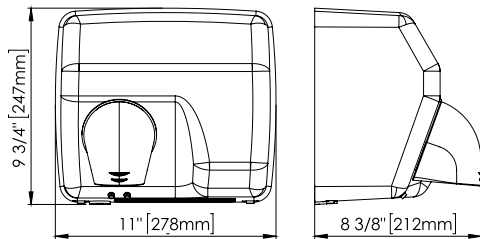

## E85-UL

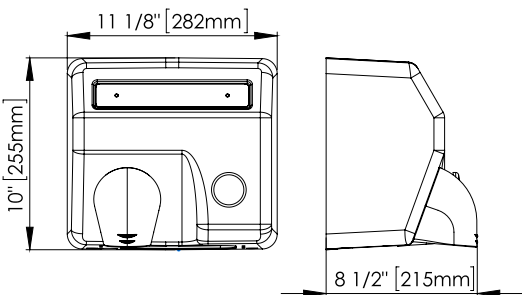

## Serial mounting

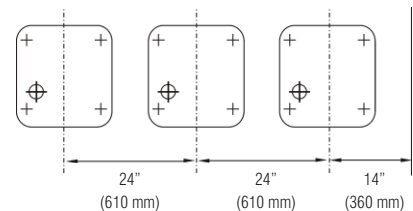

Job: \_\_\_\_\_

Architect / Engineer: \_\_\_\_\_

City / State / Country: \_\_\_\_\_

Model number: \_\_\_\_\_

Contractor: \_\_\_\_\_

Date: \_\_\_\_\_

Variations: \_\_\_\_\_

Customer / Wholesaler: \_\_\_\_\_

Quantity: \_\_\_\_\_

Saniflow Corp reserves the right to make changes and/or modifications to the products and their specifications without warning or notice.

For further info please contact SANIFLOW on: Toll free: **1-877-222-9125** or visit our website at **www.saniflowcorp.com**

Tel: +1 (305) 424 2433 Fax: +1 (305) 424 2435 · [sales@saniflowcorp.com](mailto:sales@saniflowcorp.com)

[HandDryerSupply.com](http://HandDryerSupply.com) | 804-859-2498 | [sales@handdryersupply.com](mailto:sales@handdryersupply.com)