

**CP0016H-ASTM / CP0016HCS-ASTM**

**General Description**

- Surface-mounted baby changing stations made of bacterial-resistant polypropylene (CP0016H-ASTM and CP0016HCS-ASTM) and with stainless steel AISI 304 exterior (only CP0016HCS-ASTM).
- High level of safety and cleanliness.
- Models with high strength and durability, suitable for high traffic facilities.
- Trendy and stylish design.
- Biocote® antimicrobial additive embedded into its surface.
- With a pair of bag hooks to hang personal belongings close and at hand.
- In compliance with the American Standard ASTM F2285-04 and the European EN 12221-1 and EN 12221-2 standards.

**Components & Materials**

- **CP0016H:** surface-mounted baby changing station made of polypropylene in white finish.
- **CP0016HCS:** surface-mounted baby changing station made of polypropylene and with a stainless steel AISI 304 exterior, in satin finish.
- **BED:** approximately 295 in<sup>2</sup> contoured changing surface area is made of polypropylene in white finish Biocote® antimicrobial additive embedded into its surface, easy cleaning while reducing the growth of odor causing bacteria and staining microbes.
- **LINER DISPENSER:** with lock is made of polypropylene and holds approximately 80 bed liners, minimizing operator refills and discouraging potential vandalism.
- **OPEN/CLOSE MECHANISM:** concealed from the user's view, it consists of a pair of reinforced hinges and a pneumatic cylinder, ensuring high durability and a smooth opening and closing of the baby changing station.
- **MOUNTING CHASSIS:** made of steel with a cataphoresis treatment. The corresponding mounting hardware is supplied, for an easy installation of unit onto the wall.
- **FRONTAL CHASSIS:** (only CP0016HCS) made of one-piece AISI stainless steel, 1/32" thick, fixed to the bottom of the bed by means of 4 bolts and nuts, ensuring that hardware is concealed for user's safety. Easy cleaning and blends with other stainless steel accessories in the washroom.

**Technical Specifications**

Dimensions	L:33 7/8" x W:3 7/8" (closed) / 22 1/2" (open) x H:18 7/8"
Weight (empty)	27.12 lb (CP0016H) 35.3 lb (CP0016HCS)
Liner dispenser capacity	80 units
Recommended installation height	31 1/2" at lowest point
Recommended installation height (handicapped)	27 1/2" at lowest point

**Operation**

Open the BabyMedi® baby changing station. Place the baby in the center of the bed and secure with strap to change your baby's diapers. Close the BabyMedi® station after use.

For safety measures, never leave child unattended on the baby changing station. Avoid accidents by utilizing the safety strap.

Please mark the selected item



code  
**CP0016H-ASTM**

material  
polypropylene  
finish  
white





code  
**CP0016HCS-ASTM**

material  
polypropylene /  
stainless steel  
finish  
white / satin



Saniflow Corp reserves the right to make changes and/or modifications to the products and their specifications without warning or notice.

For further info please contact SANIFLOW on: Toll free: **1-877-222-9125** or visit our website at **www.saniflowcorp.com**  
Tel: +1 (305) 424 2433 Fax: +1 (305) 424 2435 · **sales@saniflowcorp.com**

**HandDryerSupply.com | 804-859-2498 | http://www.handdryersupply.com**

## Installation

According to the installation and safety instructions manual supplied with the unit.

**IMPORTANT:** in order to ensure BabyMedi is properly installed it is recommended that a qualified person carries out the installation of the unit. The unit must be properly installed on a wall that is able to sustain considerable weight and that can accommodate the supplied installation hardware.

## Certificates & Qualifications

Unit shall be ASTM approved, according F2285-04 Standard and GS according EN 12221-1 and EN 12221-2 standards.

## Ideal location

Public spaces such as, shopping centers, airports, public buildings, childcare centers, etc. Models suitable for high traffic facilities with high strength and durability.

**IMPORTANT:** the Congress of the United has taken a further step towards gender equality by implementing law H.R.5147-Babies Act. (10/07/2016). By this law, the American Government states that restrooms, both for men and women, in public buildings all around the country, must have diaper changing facilities in place.

## Guide specification

Surface-mounted baby changing stations made of bacterial-resistant polypropylene (CP0016H and CP0016HCS) and with stainless steel AISI 304 exterior (only CP0016HCS).

BabyMedi® changing stations offer a very high level of safety and cleanliness being the ideal solution for public spaces such as, shopping centers, airports, public buildings, childcare centers, etc. Models suitable for high traffic facilities with high strength and durability.

Their trendy and stylish design, allow these baby changing stations to blend into any space perfectly.

Biocote® antimicrobial additive, based on ion silver technology, is embedded into its own surface, promoting an easy cleaning and reducing the growth of odor causing and staining microbes.

BabyMedi® baby changing stations are assembled with child protection straps made of nylon material.

Includes a pair of bag hooks, one of each side, to hang personal belongings.

BabyMedi® units fully comply with the American standard ASTM F2285-04 and the European EN 12221-1 and EN 12221-2 standards that require baby changing stations be able to support a 110 lb static load test during one hour. Moreover, units tested in our own laboratories have withstood loads over 220 lb.

## Overall dimensions:

L:33 7/8" x W:3 7/8" (closed)/ 22 1/2" (open) x H:18 7/8"

Weight: 27.12 Lbs. (CP0016H) / 35.3 Lbs. (CP0016HCS)

## MOUNTING

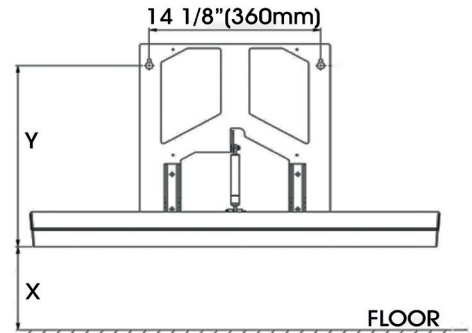

## CP0016H-ASTM / CP0016HCS-ASTM

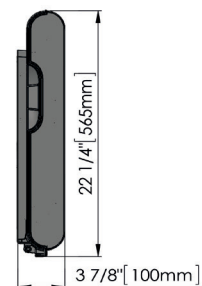
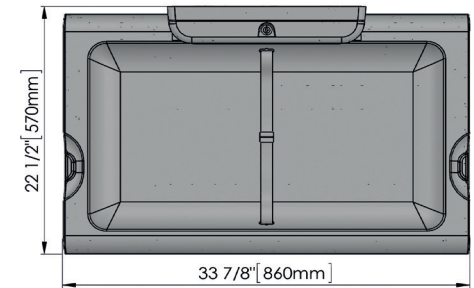
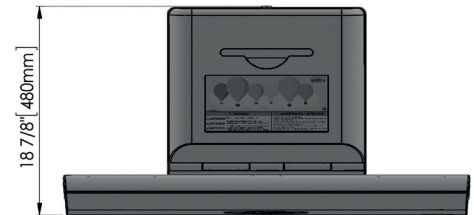

## Recommended heights from floor

	Male	Female	Disabled
<b>x</b> To bottom of unit	31 1/2" (800mm)	31 1/2" (800mm)	27 1/2" (700mm)
<b>y</b> To mounting brackets	16 3/8" (415mm)	16 3/8" (415mm)	12 13/32" (315mm)

Job: \_\_\_\_\_

Architect / Engineer: \_\_\_\_\_

City / State / Country: \_\_\_\_\_

Model number: \_\_\_\_\_

Contractor: \_\_\_\_\_

Date: \_\_\_\_\_

Variations: \_\_\_\_\_

Customer / Wholesaler: \_\_\_\_\_

Quantity: \_\_\_\_\_

Saniflow Corp reserves the right to make changes and/or modifications to the products and their specifications without warning or notice.

For further info please contact SANIFLOW on: Toll free: **1-877-222-9125** or visit our website at **www.saniflowcorp.com**

Tel: +1 (305) 424 2433 Fax: +1 (305) 424 2435 · [sales@saniflowcorp.com](mailto:sales@saniflowcorp.com)

[HandDryerSupply.com](http://www.handdryersupply.com) | 804-859-2498 | <http://www.handdryersupply.com>