

Auto Faucet

Deck-Mounted

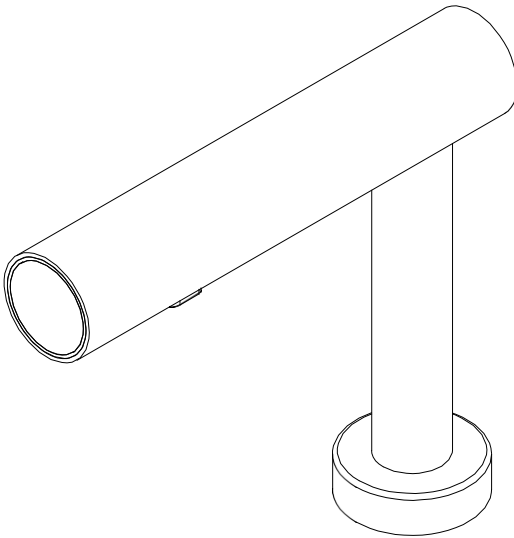

Model : EcoTap-D FA

HandDryerSupply.com | [804-859-2498](tel:804-859-2498) | sales@handdryersupply.com

Unit Size: mm (inch)

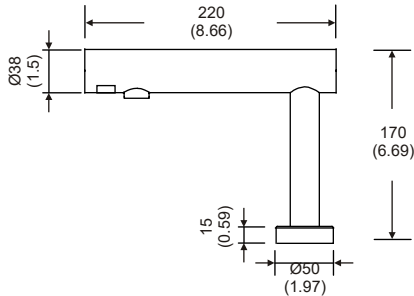

TECHNICAL SPECIFICATIONS

ITEM CATEGORY

PERFORMANCE DATA

Input Voltage	100-240 Vac, 50/60 Hz
Output Voltage	6 VDC Plug-In Adaptor
Applicable Water Temperature	4-85 °C (39-185 °F)
Operating Water Pressure	10-100 PSI
Sensing Range	Standard 4.72" \pm 0.79" [120 mm \pm 20 mm], Infrared Sensor
Shut-off Delay Time	0.5-1 second
Time Out Setting	60 seconds auto shut off
Flowing Volume	1.9, 3.8 or 8.3 LPM [0.5, 1 or 2.2 GPM] (Optional)
Standby Power	0.1 W
Net Weight	1.2 kg [2.64 lbs]
Shipping Weight	2.1 kg [4.62 lbs]
Spout Type	Stainless steel (#304), Satin finished (t:3.0 mm & 1.5 mm)
Spout Unit Size	50 mm (W) x 170 mm (H) x 220 mm (D) [1.97" (W) x 6.69" (H) x 8.66" (D)]

Installation

1. The center of the mounting hole to the edge of the basin and to the edge of the wall should be at least 30-40 mm (1.18-1.57"). Otherwise the mounting nut would not fit. Ensure a proper sensing distance.

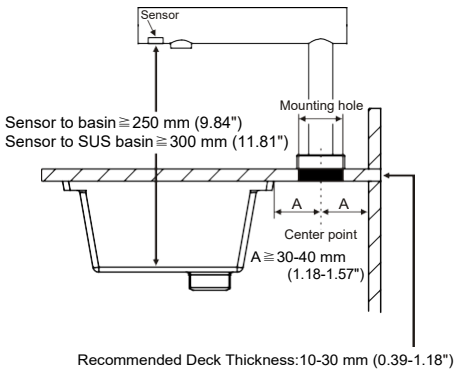

2. Drill a hole (size: 35 mm/ 1.37") on the basin. Installation location to be decided by the site owner.

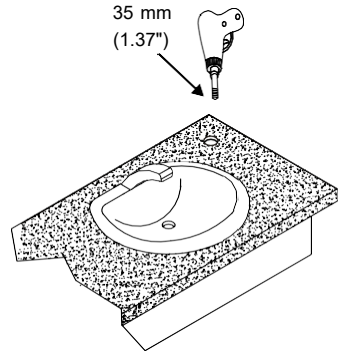

3. Mounting steps of the spout:

- A. Insert the shaft of the spout through the hole on the basin.
- B. Thread in the rubber pad, the stainless steel washer, and the plastic mounting nut.
- C. Fasten with the hex tool.

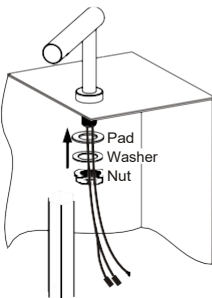

4. With the arrow on the side of the solenoid pointing up, as shown, fasten the water outlet hose with the top connector.

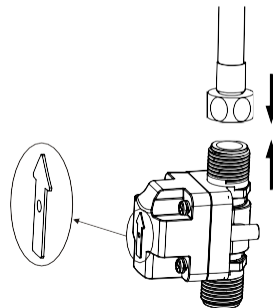

Installation

5. Fasten the water inlet tube to the other end of the solenoid valve.

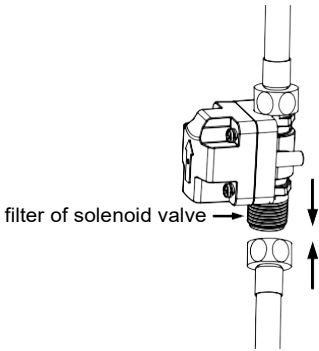

6. Fasten the other end of the water inlet tube to the tri-valve.

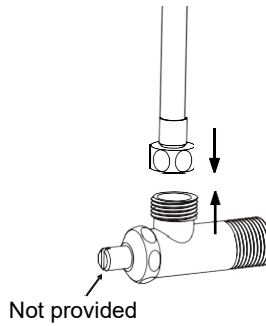

7. Connect the solenoid cable A side with B side.

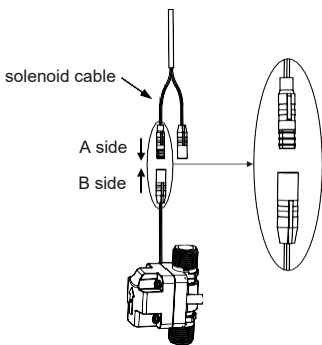

8. Connect the adaptor cable A side with B side.

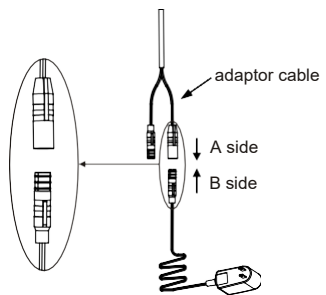

Installation

9. Install the solenoid valve under the counter.

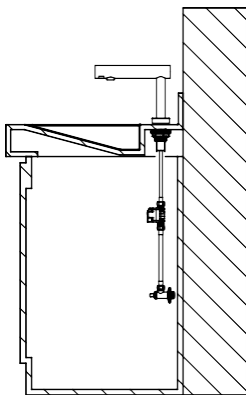

Installation Height

Recommended mounting height: Please install it based on the height of deck on-site.

Recommended deck thickness: 10-30 mm (0.39-1.18")

Operation

- No-touch operation.
- Place hands under the faucet.
- Once the sensor is activated, water will flow automatically.
- Once hands leave the sensing range, water will stop flowing automatically.

Cleaning and Maintenance

Periodic cleaning of the unit is recommended to ensure optimal performance.

- Disconnect the electrical supply.
- Do not flush with water.
- Wipe the cover with a damp cloth and mild cleaning solution. Do not soak. Never use abrasives to clean the cover.
- Clean the filter every three months to make sure the outlet is free from obstruction.



Diagnostics and Remedies

Malfunction Situation	Potential Reasons of Malfunction	Troubleshooting
No Function and there is No LED when hands are in the sensing range	The power is not connected.	Examine the power supply with multimeter to check power connector.
	Electric circuit board is damaged.	Please contact the distributor for assistance.
	Adapter is out of order.	Replace a new adapter.
No Function but the LED is steady blue when hands are in the sensing range	Water supply is not turned on.	Turn on the water supply.
	Solenoid valve terminal is loose.	Reconnect solenoid valve terminal.
	Solenoid valve failure.	Replace a new solenoid valve set.
Water runs nonstop after 60 seconds	There is dirt on the sensor window.	Clean the sensor window with neutral cleaning solution.
	Solenoid valve failure.	Replace a new solenoid valve set.
Water runs without use	There is dirt on the sensor window.	Wipe the sensor window with neutral cleaning solution.
Unstable water flow	Electric circuit board is damaged.	Please contact the distributor for assistance.
Reduced water volume	Water supply is low.	Regulate the valve to increase the water supply.
	Filter of solenoid valve is clogged.	Clean the filter of solenoid valve.
	Aerator is clogged.	Clean impurities from the aerator.
LED board is damaged	Electric circuit board is damaged.	Please contact the distributor for assistance.

Diagram

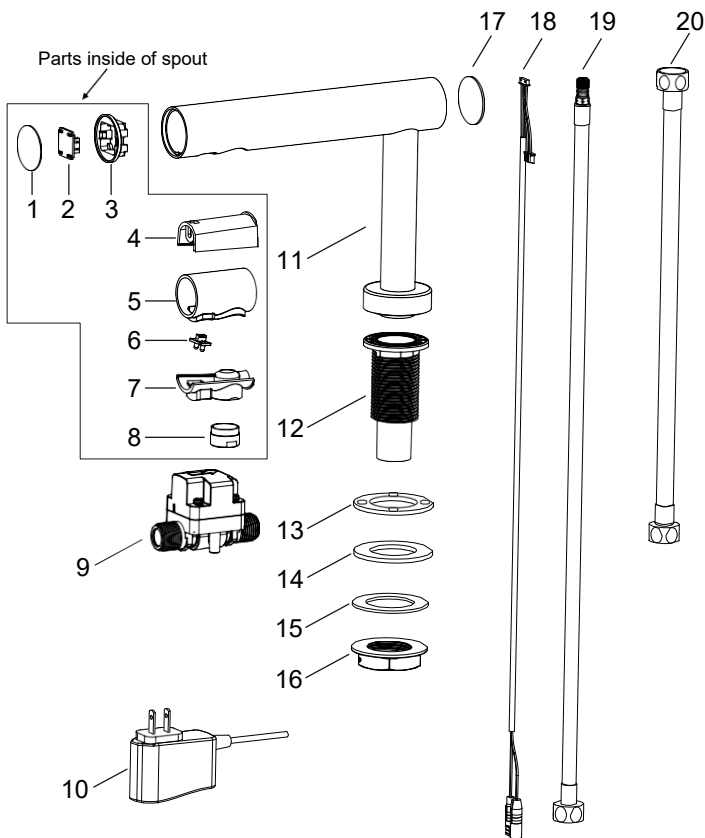

Repair Parts List

Key	Description
1	Name plate - front
2	LED light panel
3	Light leading pad
4	Water outlet mounting set - upper
5	Water outlet rubber
6	Sensor
7	Water outlet mounting set - lower
8	Nut
9	Solenoid valve
10	Adaptor
11	Spout
12	Air outlet shaft
13	Rubber washer
14	Pad
15	Washer
16	Air outlet shaft screw nut
17	Name plate - back
18	Cable wire - 800 mm in total
19	Hypertension flex hose - 800 mm in total
20	Flex hose - 300 mm