

dyson airblade tap

LOW VOLTAGE AND HIGH VOLTAGE TECHNICAL SPECIFICATION

Electrical

Input voltage: Low Voltage = 110-127 V, High Voltage = 208-240 V

Frequency: Low Voltage = 50 or 60 Hz, subject to voltage (85-115 V at 50 Hz; 85-130 V at 60 Hz); High Voltage = 50 & 60 Hz

Rated power: 1400 W

Motor type: Dyson digital motor – V4 brushless DC Motor

Motor switching rate: 6,100 per second

Motor speed: 92,000 rpm

Amp: Recommended dedicated 15 amp circuit, Low voltage = 11.7 amps at 120V, High voltage = 7.3 amps

Operating temperature range: 32° – 104°F

Heater type: None

Standby power consumption: Less than 0.5 W

Construction

Tap construction: Stainless steel (brushed)

Lead Free

Under counter motor bucket: Molded ABS (main unit) also uses polycarbonate and polypropylene

Exterior screw type: Torx T15

Water ingress protection rating to IP35

Filter

Double-life HEPA filter (glass fiber and fleece prelayer)

Bacteria removal 99.97% at 0.3 microns

Operation

Touch-free infra-red activation

Hand dry time measurement: 14 seconds*

Operation lock-out period: 30 seconds

Airspeed at apertures: 420 mph

Maximum Altitude: 2,000m/6,561 ft.

Operating airflow: Up to 7.92 gal/sec and 63.5 CFM

Rated operating noise power: 85 db(A)

Water operation

Water flow rate: 1.06 gal/min

Tap Aerator: 0.5 gal/min aerator outlet (Note: Optional .35 gal/min multi spray laminar aerator available as a service part)

Tap power supply: Mains supply

Water temperature control: Thermostatic mixer recommended (not supplied)

Water pressure required: 14.5-116 psi

Logistics

Serial number prefix: AB09 AN5; AB10 AN6; AB11 AN7

Net weight: AB09 9.5 lbs.; AB10 10.1 lbs.; AB11 19.7 lbs.

Packaged weight: AB09 13.4 lbs.; AB10 14.3 lbs.; AB11 25.9 lbs.

Packaged dimensions: AB09 (H) 11⁷/₈" × (W) 11¹/₈" × (D) 11¹/₄"; AB10 (H) 10⁷/₈" × (W) 17¹/₄" × (D) 11"; AB11 (H) 11⁷/₈" × (W) 24" × (D) 14³/₄"

UPC barcodes: Low Voltage – AB09: 885609001500, AB10: 885609001494, AB11: 885609001487; High Voltage – AB09: 885609004402, AB10: 885609004419, AB11: 885609004426

Standard guarantee

5 year parts and 5 year limited labor warranty



Product range (Select one)

AB09 Short

Part number/SKU

Low Voltage: 301848-01

High Voltage: 301841-01

AB10 Long

Part number/SKU

Low Voltage: 301849-01

High Voltage: 301842-01

AB11 Wall

Part number/SKU

Low Voltage: 301850-01

High Voltage: 301843-01



Sink specifications

The Dyson Airblade™ Tap is compatible with most sink types. Ensure plugs are not installed in the sinks. See the Tap Pre-Installation Guide for more details.

Sink dimensions: All sink measurements are internal unless stated otherwise. Sink width – Min.: 13³/₄", Front to back – Min.: 11³/₄"; Sing depth – Min. 4"; Max. sink depth – AB10 only: 7⁷/₈" (External measurement of vessel sink).

Sink materials: Sinks with highly polished surfaces should be avoided e.g. shiny chrome. Porcelain or brushed metal are ideal.

Accreditations

Carbon Trust

HACCP International

NSF International

AB09 Short and AB11 Wall are ADA compliant

Contributes to LEED certification



The Carbon Reduction Label is the registered trade mark of the Carbon Trust. HACCP International non-food certification mark is the registered trademark of HACCP International. HACCP International have certified Dyson products based on their recommended installation and operating conditions. The NSF logo is the registered trade mark of NSF International.

*Dry time measured using Dyson test method 769 based on NSF P335 using a measurement of 0.1g residual moisture.

For more information, please contact Dyson: 1-888-397-6622, www.dysonairblade.com, airbladeinfo@dyson.com

dyson airblade tap

TECHNICAL SPECIFICATION

AB AB AB
09 10 11



FRONT ELEVATION

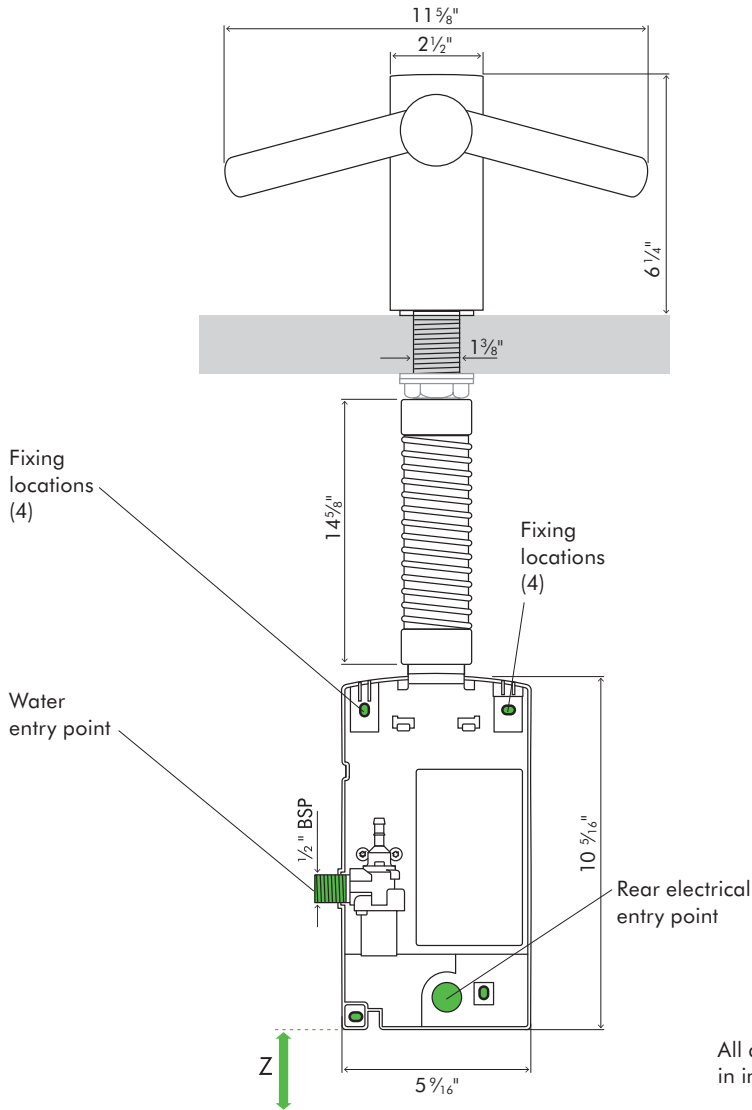

SIDE ELEVATION

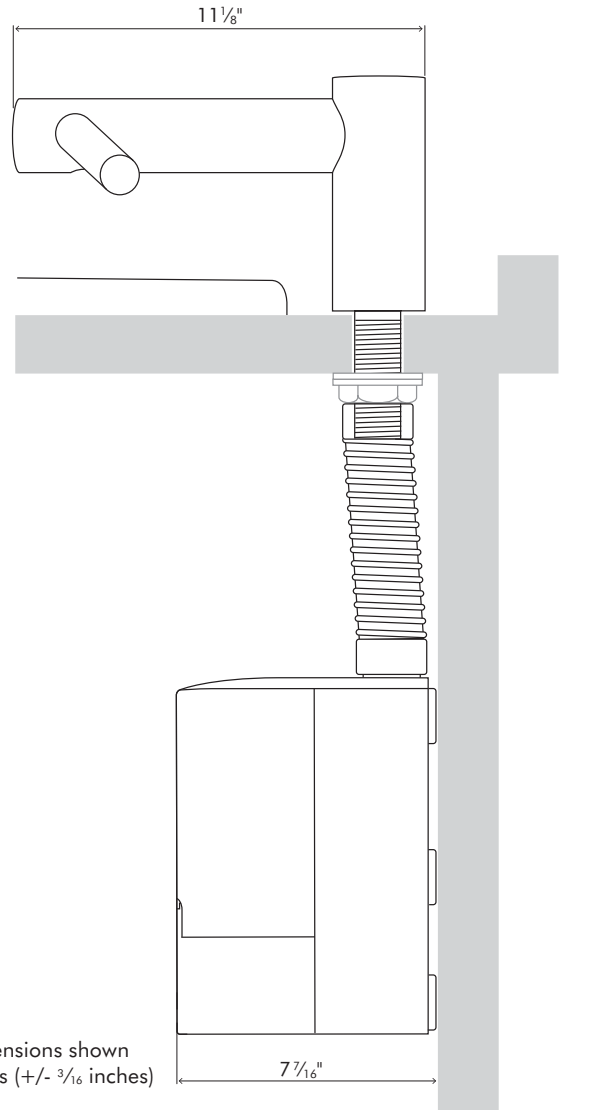

All dimensions shown in inches (+/- 3/16 inches)



Tap dimensions

AB09 Height 6 1/4" Width 11 5/8" Depth 11 1/8"

Motor bucket dimensions

AB09 Height 10 5/16" Width 5 5/16" Depth 7 7/16"

Minimum clearance

Z 4" clearance from floor. (ADA requires 9" toe clearance)

dyson airblade tap



TECHNICAL SPECIFICATION

AB
09 AB
10 AB
11

FRONT ELEVATION

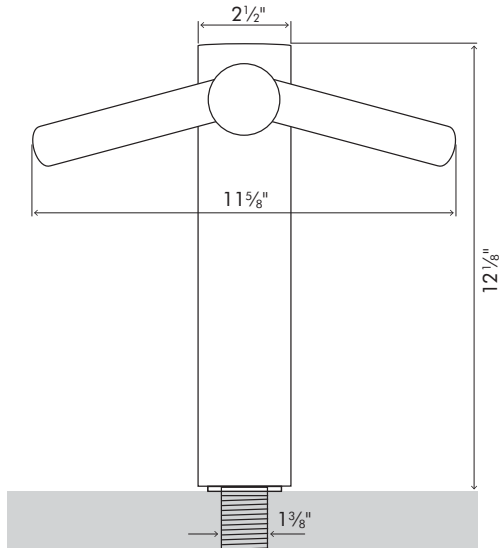

SIDE ELEVATION

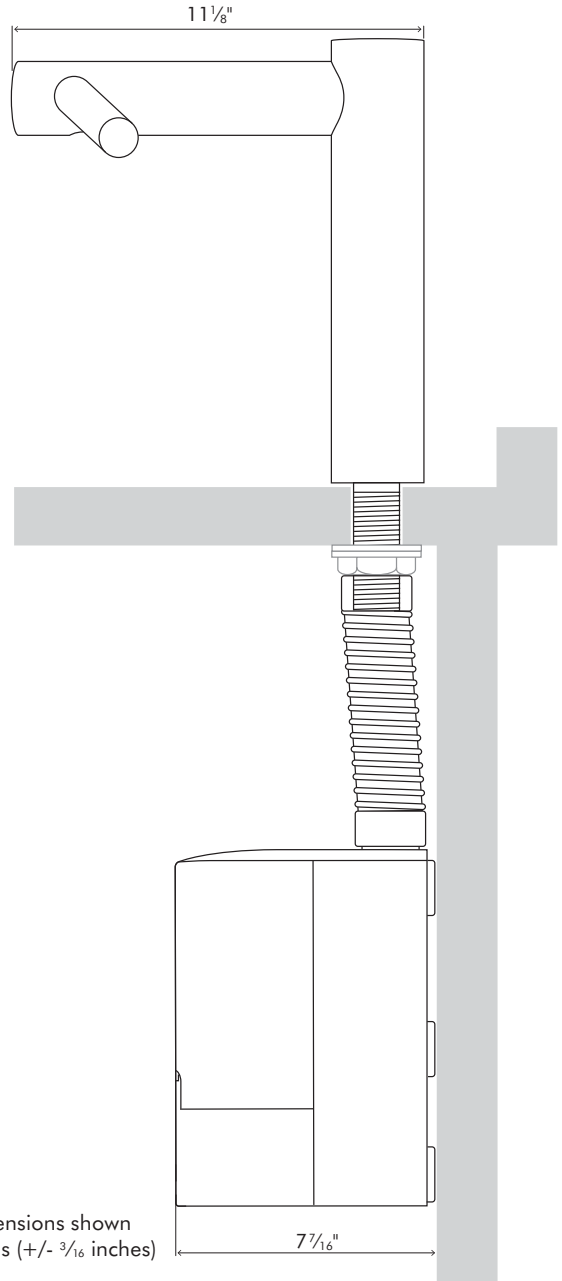

Fixing locations (4)

Water entry point

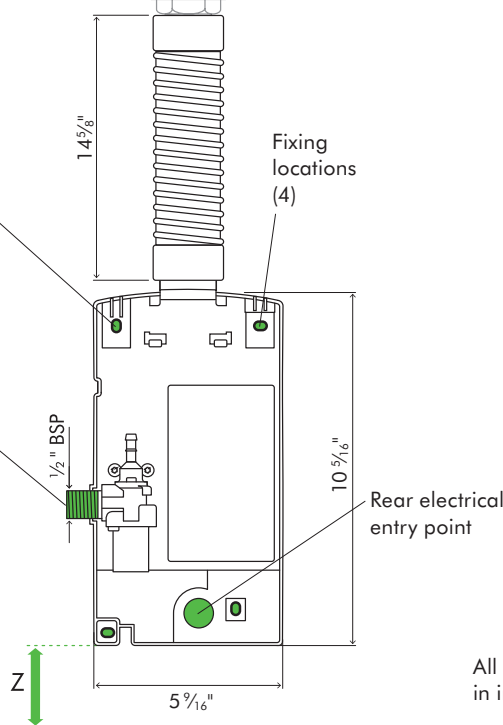

All dimensions shown in inches (+/- 3/16 inches)

FLOOR

Tap dimensions

AB10 Height 12 1/8" Width 11 5/8" Depth 11 1/8"

Motor bucket dimensions

AB10 Height 10 5/16" Width 5 9/16" Depth 7 1/16"

Minimum clearance

Z 4" clearance from floor. (ADA requires 9" toe clearance)

dyson airblade tap

TECHNICAL SPECIFICATION

AB AB AB
09 10 11



FRONT ELEVATION

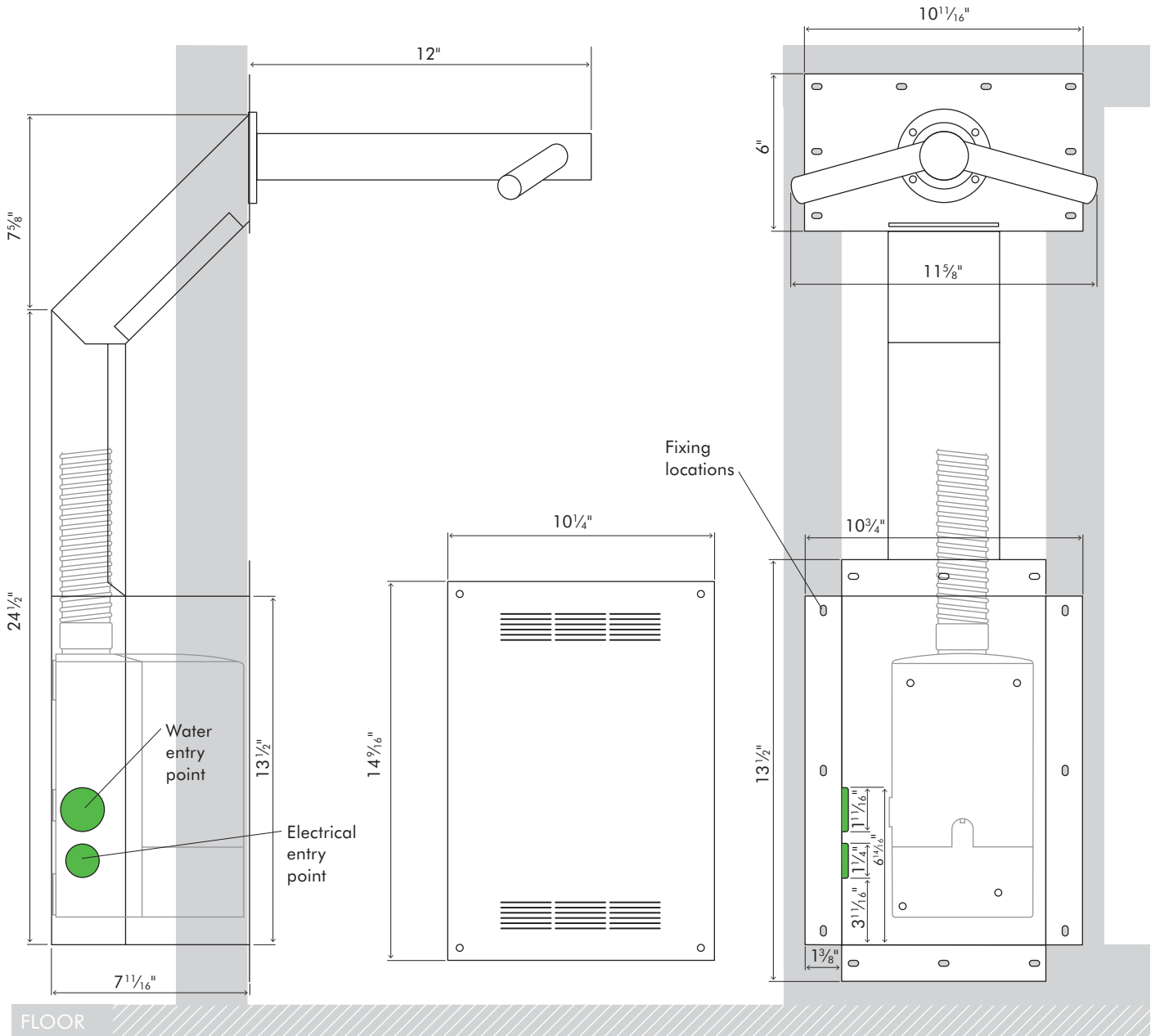

Tap dimensions

AB11 Length 12¹/₁₆" Width 11⁵/₈"

Motor bucket dimensions

AB11 Height 10⁵/₁₆" Width 5⁵/₁₆" Depth 7⁷/₁₆"

All dimensions shown in inches (+/- ³/₁₆ inches)

For more information, please contact Dyson:

1-888-397-6622

www.dysonairblade.com

airbladeinfo@dyson.com