



**BUILDING VALUE SINCE 1906**

# TrimDry™ B-7120, B-7128 ADA Dryer Troubleshooting and Information Guide

Effective 9/20/21

**All Bobrick dryers require cleaning every 6 months to ensure that they function effectively. Please note that failing to clean the dryer may result in malfunction and can void the warranty.**

(Refer to page 7 of the [Dryer Troubleshooting and Information Guide](#) for Routine Maintenance Instructions)

[www.bobrick.com](http://www.bobrick.com)

## **BOBRICK DOMESTIC**

Email: [customerservice@bobrick.com](mailto:customerservice@bobrick.com)

### **Corporate Office - Los Angeles - Bobrick Washroom Equipment**

6901 Tujunga Avenue, North Hollywood, California 91605-6213

Customer Service: 818.982.9600, Fax: 818.503.9287

### **New York - Bobrick Washroom Equipment, Inc.**

200 Commerce Drive, Clifton Park, New York 12065-1350

Customer Service: 518.877.7444, Fax: 518.877.5029

### **Canada - Bobrick Washroom Equipment Company**

45 Rolark Drive, Scarborough, Ontario M1R 3B1

Customer Service: Eastern Canada: 877.423.6555, Fax: 423.765.8555

Western Canada: 877.423.6444, Fax: 423.503.8444

## **BOBRICK INTERNATIONAL**

Email: [international@bobrick.com](mailto:international@bobrick.com)

### **Corporate Office - Bobrick Washroom Equipment, Inc.**

6901 Tujunga Avenue,, North Hollywood, California 91605-6213 USA

Customer Service: +1 818.764.1000, Fax: +1 818.503.9941

### **United Kingdom Bobrick Washroom Equipment Limited**

Phone: +44 (0)20.8366.1771, Fax: +44 (0)20 8363 5794; Email: [uksales@bobrick.com](mailto:uksales@bobrick.com)

### **Australia Bobrick Washroom Equipment Pty. Ltd.**

Phone: +1800 353158, Fax: +1800 221926; Email: [australia@bobrick.com](mailto:australia@bobrick.com)

# TrimDry™ B-7120, B-7128 ADA Hand Dryer

## Contents

Page

Instructions for Using the Dryer Guide .....	3
Sample Dryer Service Information Sheet .....	4
Date Code Information .....	5
Routine Maintenance Instructions .....	6
Information and Troubleshooting .....	7
Diagnostic Sheet .....	8
Schematic Diagram .....	9
Limited Warranty .....	10

# Instructions For Using The Dryer Guide

- Signs for your safety:



General mandatory sign (to be accompanied where necessary by another sign)



Danger: Electricity

- Please fill out the Dryer Service Information Sheet completely. If a section is not necessary/available insert N/A in the space.
- If the faulty dryer has been installed for 2 months or less, then **replace complete dryer and return faulty unit to the nearest [Bobrick Customer Service Department](#)**.
- When you receive a call concerning a dryer problem inform, the customer/end user to **clean the dryer and check the motor brushes** before going on with diagnosing the problem. Fax them the cleaning instructions from the guide. If the dryer still does not function after cleaning, then continue filling out the Dryer Service Information Sheet.
- Inform the customer/end user that the malfunctioning/replaced parts must be returned to the Bobrick Customer Service Department or a charge will be made for replacement parts.



Dryer Service Information Sheet

Distributor/Rep/End-User Name: Bobrick's best

Address: 12345 Your Street, Suite 100

City: Toon Town State: Your State Zip code: 98765

Job Name: Fantasy Lane Job Location: My Town

Contact Name: Jessica Rabbit Telephone: (555) 555-3333 Fax: (555) 555-4444

Email: jrabbit@bobricksbest.com Account #: 99999 Sales order #: 246810

Invoice #: 35791 Invoice Date: 03/03/20

**Dryer Model Information:**

Automatic Dryer:  TouchButton Dryer:  (check one)

Dryer:  Dryer:  (check one)

Dryer model #/voltage: 700 115V

Quantity defective: 1 Quantity on job: 2 Date of installation: 06/03/20

Date code (as seen on bottom edge of cover on dryer UL label. For example: 04A): \_\_\_\_\_

**Dryer Information:**

When did dryer problems first occur from date of installation?

(Circle one) Upon Installation      0-2 Months      2+ Months      Out of Warranty

*If dryer problem occurred within two months of installation, REPLACE dryer and return faulty dryer.*

Does the dryer in any way function now? No (Yes or No)

Has the dryer been cleaned in the past 6 months? No (Yes or No). If No, send a cleaning sheet and await outcome.

Full description of fault: Unit would not start upon installation.

**Reference to Diagnostic Sheets:**

Problem and possible solution: Faulty controller

Problem number(s) (as seen in left margin on diagnostic sheet): # 1 F

Repair kit/parts required (if dryer needs to be returned write RETURN): Return

Part number(s) for replacements: Complete Unit Replaced on SO #: \_\_\_\_\_

**ANY DEFECTIVE PARTS MUST ACCOMPANY THIS COMPLETED SHEET TO BOBRICK'S SERVICE DEPARTMENT.**

Information sheet completed by: Your Name Completion Date: 6/6/20

Branch/Rep Firm: \_\_\_\_\_

# Date Code Information

The date code on all Bobrick Dryers is found on the upper left corner of the rating label and on the serial number label.

The date code will contain two digits and one letter.

The digits designate the week and the letter designates the year.

Example: 30Z      week thirty, year 2000.

All digits and letters are in ascending order.

Weeks are numbered from 1 to 52 for each year.

- X = 2021
- W = 2020
- V = 2019
- U = 2018
- T = 2017
- S = 2016
- R = 2015
- P = 2014
- N = 2013
- M = 2012
- L = 2011
- K = 2010
- J = 2009
- H = 2008
- G = 2007
- F = 2006
- E = 2005
- D = 2004
- C = 2003
- B = 2002
- A = 2001
- Z = 2000
- Y = 1999
- X = 1998
- W = 1997
- V = 1996
- U = 1995
- T = 1994
- S = 1993
- R = 1992
- P = 1991
- N = 1990
- M = 1989



**Rating Label**

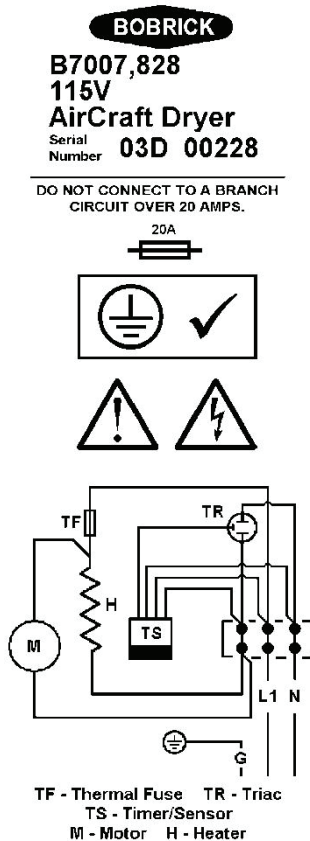

← Date code and serial number

HDI 0700F5U828      1  
 0403 W1234567 123456

**Serial Number Label**

# Routine Maintenance Instructions

- All Bobrick Dryers require cleaning every 6 months to ensure that they function effectively. Please note that failing to clean the dryer may result in malfunction and can void the warranty.
- If the dryer is installed in an area prone to dust and dirt this cleaning procedure should be carried out more frequently.
- Check the length of motor brushes, where applicable, when performing the cleaning procedure.

## Cleaning Instructions:



Warning  
Risk of electric  
shock



Disconnect power  
supply before  
removing cover

### a) The Exterior of Cover

Should be cleaned with a damp cloth, **DO NOT** use aggressive cleaners or solvents as they may permanently damage the surface.

Bobrick dryers are drip proof (IP21 or better, see rating label). **DO NOT** spray with liquids to an extent that they could enter the unit.

### b) The Interior

Having turned off all power to the dryer, remove the cover.

Using a small brush or vacuum, carefully clean out the build up of dust and lint.

Check the length of the motor brushes. If less than 1/2" replace. Check that motor brushes are installed correctly and that brushes are worn evenly.

Replace the cover.

Turn the power back on.

# Information and Troubleshooting for the TrimDry™ B-7120, B-7128 ADA Hand Dryer

For complete set of Installation Instructions refer to form No. 712-69

## Information about the Dryer:

- Surface-Mounted, ADA compliant.
- Durable, steel cover with painted finish or stainless steel with satin finish.
- Dual air blowers provides comfortable hand drying in less than 25 sec.
- Quiet operation, 73 dBA.

## Product Types:

B-7120 White Cover (pictured).

B-7128 Stainless Steel Cover.

Both available as 115V or 208 – 240V.



## Electrical Characteristics:

Model B-7120 White Painted Steel Cover and B-7128 Stainless Steel Cover, 115V AC, 15 Amp, 1725 Watts, 50/60 Hz, Single Phase, cULus listed.

Model B-7120 White Painted Steel Cover and B-7128 Stainless Steel Cover, 208–240V AC, 6.8-7.8 Amp, 1400-1900 Watts, 50/60 Hz, Single Phase; cULus listed, VDE approved and CE marked.

## Removal of Cover:

1. Remove two screws, from the bottom of the dryer. Rotate the bottom of the cover forward about 30°, then lift the cover from the mounting base.

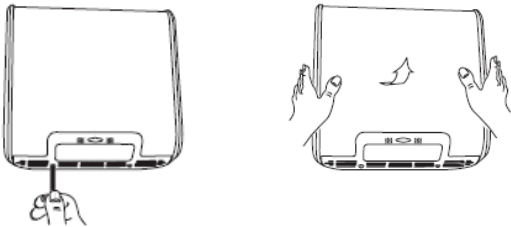

Warning  
Risk of electric  
shock



Disconnect power  
supply before  
removing cover

## If a fault occurs with the dryer:

1. Check that the electrical supply is working properly.
2. Check that the circuit breaker is switched on.
3. Clean the sensor lens.

## Replacement Parts:

700-121	Motor Brushes	7120-150 230V
712-360	B-7120/7128 115V Sensor	7128-150 115V Dryer Cover (Stainless)
712-361	B-7120/7128 230V Sensor	7128-150 230V
7120-150 115V	Dryer Cover (White)	

# Diagnostic Sheet for TrimDry™ B-7120, B-7128 Dryers

<b><u>Problem</u></b>	<b><u>Possible Cause</u></b>	<b><u>Possible Solution</u></b>
1. Dryer does not run	a) No electricity supply b) Dirty control lens c) Installation fault  d) Worn motor brushes  e) Element open circuit f) Control nonstart g) Triac open circuit	Check main supply / wiring Clean control lens Check circuit diagram label for possible wiring mistakes Check length of brushes; replace if less than 1/2" Return dryer to Bobrick for repair Return dryer to Bobrick for repair Return dryer to Bobrick for repair
2. Sparks from dryer	Worn motor brushes	Replace motor brushes
3. Dryer runs at low speed	a) Worn motor brushes b) Triac halfwave c) Control halfwave	Replace motor brushes Return dryer to Bobrick for repair Return dryer to Bobrick for repair
4. Dryer runs continuously	a) Triac short circuit b) Control faulty	Return dryer to Bobrick for repair Return dryer to Bobrick for repair
5. Dryer cycles on and off	Control	Return dryer to Bobrick for repair
6. Dryer sometimes runs	Dirty control lens Control	Clean control lens Replace control
7. Dryer is oversensitive	Control	Replace control
8. Dryer blows cold air or motor runs fast	Heating element	Return dryer to Bobrick for repairs
9. Grinding noise from dryer	a) Worn motor brushes b) Fan cage is bent or damaged	Replace motor brushes Return dryer to Bobrick for repairs
10. Dryer does not run and heating element glows	Worn motor brushes	Replace motor brushes; if still not functioning after replacing the motor brushes, return dryer to Bobrick for repairs.



## Schematic Diagram 115V Dryer

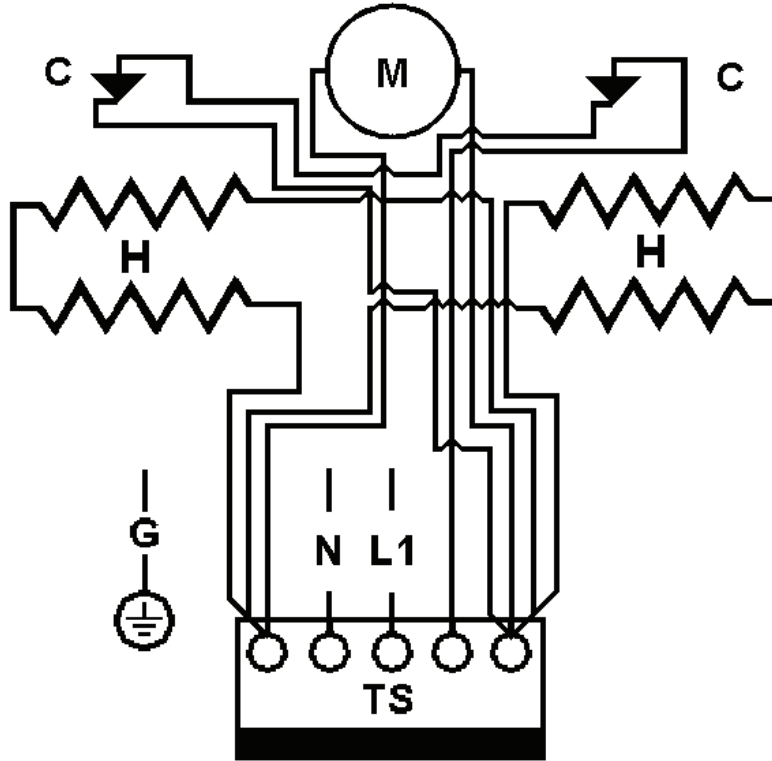

## Schematic Diagram 208-240V Dryer

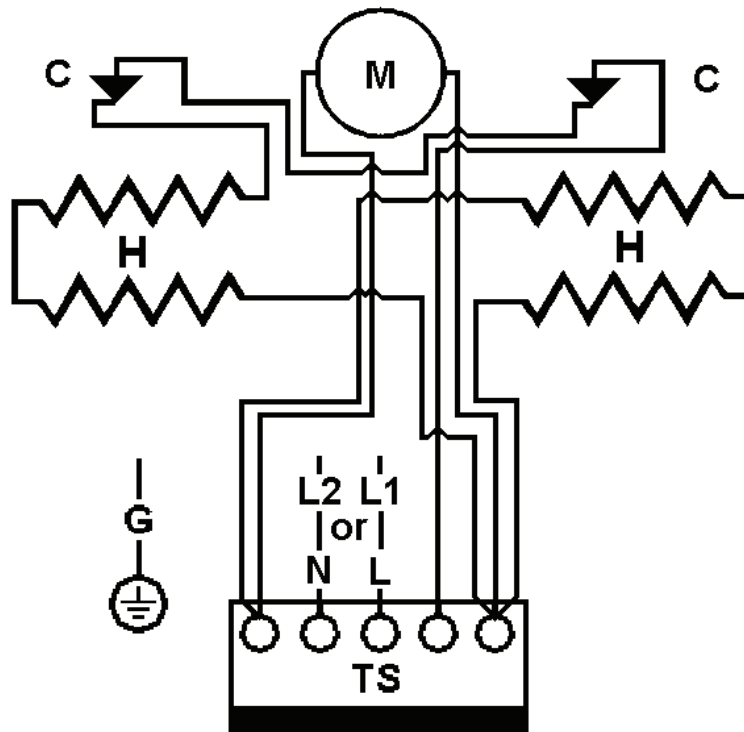

# Limited Warranty

The Bobrick B-7120 and B-7128 Dryer of the serial number(s) indicated herein, and all parts are warranted to the original owner of the installed unit for ten years from date of original purchase against defects in factory workmanship or material under normal use and service\*..

This warranty is limited to repair or exchange of defective parts at the option of Bobrick.

**THIS WARRANTY DOES NOT COVER ACCIDENTAL DAMAGE, IMPROPER HANDLING OR INSTALLATION, OR REPAIRS MADE BY UNAUTHORIZED PERSONS, AND SPECIFICALLY EXCLUDES CLAIMS FOR INDIRECT, ACCIDENTAL OR CONSEQUENTIAL DAMAGES TO PROPERTY. THE IMPLIED WARRANTIES OF MERCHANTABILITY AND FITNESS FOR A PARTICULAR PURPOSE ARE LIMITED TO THE SAME DURATION OF THE ABOVE WARRANTY.**

Some states do not allow the exclusion of incidental or consequential damages, so the above limitation or exclusion may not apply to you. Some states do not allow limitations on how long an implied warranty lasts, so the above limitation may not apply to you. This warranty gives you specific legal rights, and you may also have other rights which vary from state to state.

**\* Normal service constitutes performing the following preventive maintenance procedures at six-month intervals:**

**Clean any lint, dust or grease from air-intake grille and air-outlet grille.**

**Labor costs for preventive maintenance shall be at owner's expense.**

For repair or exchange of defective part, send the part together with installation date and serial number to Bobrick.